

# ULTIMATE BEARING CAPACITY OF CIRCULAR FOOTING ON LAYERED SOIL

Vipin Chandra Joshi<sup>1</sup>, Rakesh Kumar Dutta<sup>2</sup>, and Rajnish Shrivastava<sup>3</sup>

## ABSTRACT

The bearing capacity equations developed in literature consider homogenous soil below the base of the footing. But in actual practice soil mass is non homogenous and anisotropic. Therefore, while deducing the expression of the bearing capacity in case of circular footing resting over layered deposits, one has to take into account for a layered profile of soil. The paper presents the theoretical equation for the bearing capacity of a circular footing resting on layered soil profile using punching shear failure mechanism following projected area approach. The punching mechanism has been adopted while at ultimate load the mechanism of punching shear failure developed in dense sand has a parabolic shape when full mobilization of shear force into failure surface is taken into consideration otherwise punching failure is the actual failure while punching in the lower layer continues to a larger extent depending upon the loading at interface. For the analysis part frustum is considered to be a linearize curve for the actual shape of failure and a bearing capacity expression is deduced adopting certain assumptions. Stresses acting on the frustum have been analyzed and after series of integration bearing capacity equations is generalized. The proposed bearing capacity equation has been derived as a function of upper and lower layer properties. Finally the parametric study is carried out. The results of the parametric study were compared with the available equations in literature for the circular footing. Further, the results were validated with the experimental results reported in literature by other investigator.

*Key words:* Ultimate bearing capacity, layered soil, parametric study, theoretical equation.

## 1. INTRODUCTION

Footing is required to transmit the load of the superstructure to deep below the ground. In general footings may be shallow or deep depending upon the depth to width ratio. Considerations may be taken for the safe transmission of load beneath footing such as safe against shear and settlement. Most of the bearing capacity equations developed in literature considers homogenous soil deposits below the base of the footing. But in actual practice soil mass is non homogenous & anisotropic. Problem for finding the ultimate bearing capacity can be found out using analytical method and experimental method. In analytical method theory of plasticity and finite element can be used whereas in experimental method different type of model and prototypes can be considered. The objective of this study is to develop an equation for the ultimate bearing capacity of a circular footing resting on dense sand overlying saturated soft clay using a modified failure plane. For the analysis, frustum is considered to be a linearize curve for the actual shape of failure but in actual sense at ultimate load the failure surface will be a parabolic shape (Taiebat and Carter 2010) when full mobilisation of shearing resistance is acting on the failure surface ( $\delta = \phi$ ) *i.e.*, extending outwards from the base of footing to the interface of dense sand and saturated soft clay layer respectively. The punching shear mechanism followed by

projected area approach has been used in this paper to derive the ultimate bearing capacity equation. The mechanism mentioned above is adopted by other researchers also. Further, in literature, the study using punching shear mechanism followed by projected area approach has been done for the strip footing. No study is reported for the circular footing resting on layered soil using the punching shear mechanism followed by projected area approach.

## 2. BACKGROUND

Past studies in the literature have shown various equations for the bearing capacity of different types of footing resting on layered profile and using different approaches. The classical approach (Meyerhof 1974; Purusothamaraj *et al.* 1974; Hanna 1981b, 1982; Andrawes *et al.* 1996; Hanna and Meyerhof 1979; Georgiadis 1985; Oda and Win 1990; Michalowski and Shi 1995; Okamura *et al.* 1998; Abdulhazh *et al.* 2005; Carlos 2004; Zhang and Luan 2008; Huang and Qin 2009), semi empirical approach (Meyerhof 1974; Hanna 1981b, 1982; Hanna and Meyerhof 1979; Merifield *et al.* 1999), kinematic approach (Purusothamaraj *et al.* 1974; Michalowski and Shi 1995), numerical approach (Georgiadis 1985), finite element method (Hanna 1987; Yin *et al.* 2001; Zhu 2004; Szypcio and Dołżyk 2006; Zhu and Michalowski 2005; Kumar and Kouzer 2007) and artificial neural network (Padmini *et al.* 2008; Kuo *et al.* 2009; Kalinli *et al.* 2011) for calculation of ultimate bearing capacity. A detailed review of various approaches is reported by Shoaei *et al.* (2012).

Meyerhof (1974) analyzed different failure modes for dense sand on soft clay and compared the results of model test conducted on a circular footing resting on layered deposits. The results of the tests conducted and the field observations were

Manuscript received November 27, 2014; revised January 27, 2015; accepted March 13, 2015.

<sup>1</sup> Post graduate student (corresponding author), Department of Civil Engineering, National Institute of Technology, Hamirpur-177005, Himachal Pradesh, India (e-mail: chandravipin1991@gmail.com).

<sup>2</sup> Professor, Department of Civil Engineering, National Institute of Technology, Hamirpur-177005, Himachal Pradesh, India.

<sup>3</sup> Director, National Institute of Technology, Hamirpur-177005, Himachal Pradesh, India.

found to agree with the theory developed. Hanna and Meyerhof (1980) studied weak layer overlain by a strong deposit for the circular footing. Failure mechanism considered were approximations of the real failure mechanism dependent on many factors and the results were compared with model tests on circular footings on layered sand and clay for different loading conditions (vertical and inclined loading). Hanna and Meyerhof (1980) extended the previous work for dense sand overlying soft clay for circular footing. In order to reduce the effects of the analysis revision in assumptions for the punching theory was carried out. Hanna and Meyerhof (1981) investigated experimentally the ultimate bearing capacity of footings subjected to axially inclined loads by conducting tests on model strip and circular footing on homogenous sand and clay.

The development of bearing capacity equations using projected area approach has been studied for strip footing by some researchers for two-layered soil system (Kenny and Andrawes 1997; Okamura *et al.* 1998; Carlos 2004). Kenny and Andrawes (1997) have found that better and more reliable results can be obtained by employing lower values of load spread angle. A theoretical equation is also developed by Okamura *et al.* (1998) following projected area method for the strip footing. The bearing capacity of bottom clay layer is supposed to be the same as the applied vertical stress at the interface of two layers (at the base of sand block). Carlos (2004) has developed an equation for strip footing resting on two layered soil employing punching shear mode following projected area method which is more similar to the actual shape of failure, therefore closer value of mobilised angle of shearing resistance ( $\delta$ ) can be selected to that of internal angle of friction ( $\phi$ ). The suggested equation is developed through summation of forces induced and mobilised against exerting pressure at a selected strip element located in upper sand layer (Carlos 2004). Furthermore, it was reported in Shoaei *et al.* (2012) that the projected area method overestimates the bearing capacity of circular footings since the highest magnitude of  $\alpha$  has been chosen over the range of  $0^\circ$  to  $30^\circ$ . Ibrahim (2014) reported a study on the circular footing resting on dense sand overlying soft clay. It is mentioned in this study that the ultimate bearing capacity is directly proportional to the angle of internal friction of granular soil, the granular layer thickness and the foundation depth while at the same time it is inversely proportional to the footing diameter. It is further reported by Ibrahim (2014) that the punching shear and Prandtl failure will occur in the top granular soil and lower soft clay layer respectively.

The above literature indicates that most of the studies were carried out for the strip footing resting on layered soil. However, there is a paucity of analysis of the bearing capacity of circular footings resting on layered soil. This paper presents the theoretical equation along with a parametric study for the circular footing resting on layered profile using punching shear mechanism followed by the projected area approach in which external load is supposed to spread linearly from the base area of the circular footing to a larger area of sand as pressure penetrates deeply into the top layer and hence the intensity of load decreases along the depth.

### 3. METHOD OF ANALYSIS

The analysis is carried out for the bearing capacity of a circular footing as shown in Fig. 1. The footing is of radius  $r'$  embedded at depth  $D$  in a dense sand layer overlying saturated

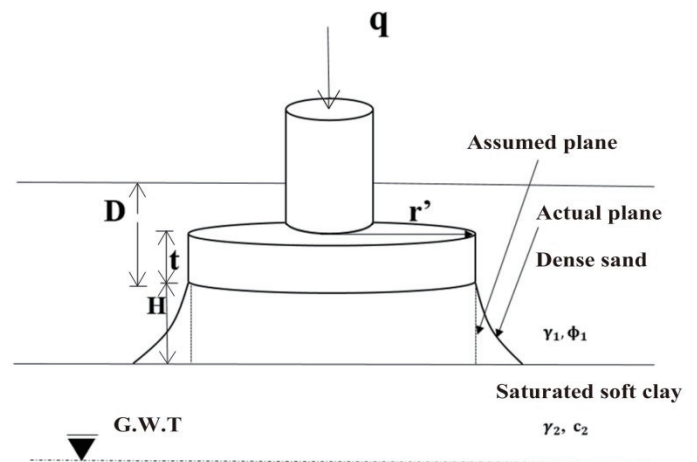

Fig. 1 Circular footing embedded in layered deposit

soft clay. The distance below the base of the footing up to interface of dense sand and saturated soft clay is taken as  $H$ . The various soil properties for the dense sand and saturated soft clay are taken as  $\gamma_1$ ,  $\phi_1$  and  $\gamma_2$ ,  $c_2$  respectively. For the analysis, punching shear mechanism has been adopted followed by projected area approach. The external load is assumed to spread linearly at an angle  $\alpha$  with respect to the vertical from the base area of circular footing to a larger area of sand as pressure penetrates deeply into the top layer and hence the load intensity decreases with depth and the frustum is considered to be a linearize curve for the actual shape of failure as shown in Fig. 2. The various assumptions made in the analysis are as under.

1. The assumptions involved in developing the theoretical model are that the failure at ultimate load is initiated by punching in the upper layer.
2. The soil above the bottom of the foundation has no shear strength; is only a surcharge load.
3. Ground surface and interface between the two layers is horizontal.
4. The footing is assumed to be rough at the base.
5. Depth of foundation is less than or equal to the diameter of circular footing.
6. The analysis has been done on the actual failure plane considered to be a frustum (best fit for the actual curve).
7. The bottom clay layer is assumed to be normally consolidated with undrained cohesion  $c$  and the top sand layer is drained.
8. The friction angle of the sand  $\phi$  and the undrained cohesion  $c$  of the clay being fully mobilised in the combined failure zones.
9. The vertical load is concentric with respect to vertical.
10. The thickness of the sand layer is smaller in comparison to the clay layer and the failure is initiated by punching in the top as well as in the bottom layer.

Further, in the analysis, a frustum as shown in Fig. 2 located at depth  $z$  from the base of the circular footing and of thickness  $dz$  is considered. The various forces considered for the analysis on this frustum are shown in Fig. 3. The passive earth pressure  $dPp$  acting on the curved surface of the frustum of thickness  $dz$  is inclined at an angle  $\delta$  to the horizontal while the total passive

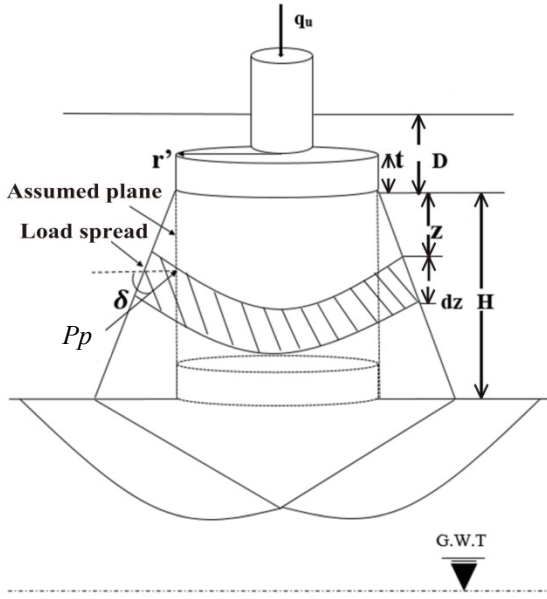

Fig. 2 Assumed failure pattern of the circular footing resting on layered soil

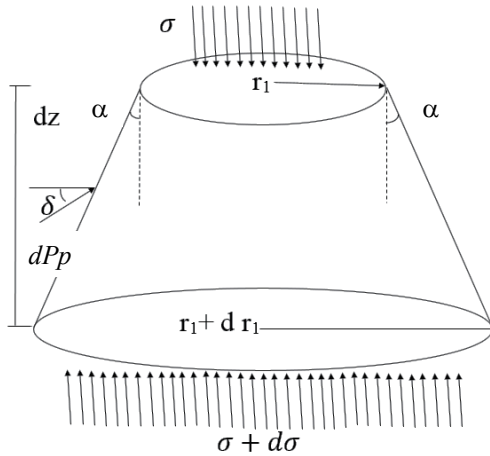

Fig. 3 Forces acting on a frustum of thickness  $dz$

pressure ( $Pp$ ) act on the punching surface created by the circular footing in dense sand. The idea behind the passive pressure to be inclined lies in the fact that it tries to resist the pressure that is exerted by foundation on the underlying soil.  $\sigma$  and  $\sigma + d\sigma$  is the vertical stress acting downward on top and upward on the bottom of the frustum of thickness  $dz$  respectively. The self weight of the frustum of thickness  $dz$  is acting in the downward direction. Using the limit equilibrium approach, the summation of all the forces acting in the vertical direction is taken equal to zero

$$\sum F_v = 0$$

$$\sigma(\pi r_1^2) - (\sigma + d\sigma)\pi R^2 - dPp_v + \gamma_1 \pi dz (R^2 + Rr_1 + r_1^2) / 3 = 0 \quad (1)$$

where,  $\gamma_1$  is the unit weight of dense sand in the frustum of thickness  $dz$

$$R = r_1 + dr_1$$

$$dPp = K_p \gamma_1 \left( D + z + \frac{dz}{2} \right) \pi (2r_1 + dr_1) dz \sec \alpha$$

$$dPp_v = dPp \sin \delta$$

Substituting the value of  $R$  and rewriting Eq. (1)

$$\sigma(\pi r_1^2) - (\sigma + d\sigma) \pi (r_1^2 + dr_1^2 + 2r_1 dr_1) - dPp_v + \frac{\gamma_1 \pi dz (3r_1^2 + dr_1^2 + 3r_1 dr_1)}{3} = 0 \quad (2)$$

Expanding Eq. (2) and neglecting the smaller quantities such as  $-\sigma(\pi dr_1^2)$ ,  $-\partial \sigma \pi dr_1^2$ ,  $-d\sigma(2\pi r_1) dr_1$ ,  $\gamma_1 \pi dz dr_1^2 / 3$  and  $\gamma_1 \pi r_1 dz dr_1$  ( $dr_1^2$ ,  $\partial \sigma dr_1^2$ ,  $\partial \sigma dr_1$ ,  $dz dr_1^2 / 3$  and  $dz dr_1$  may be small because  $d\sigma$ ,  $dr_1$  and  $dz$  are small so that the product of the multiplication can be very small) results Eq. (3).

$$-\sigma(2\pi r_1 dr_1) - d\sigma \pi r_1^2 - dPp_v + \gamma_1 \pi r_1^2 dz = 0 \quad (3)$$

Substituting,  $dPp_v = K_p \gamma_1 (D + z + dz/2) \pi (2r_1 + dr_1) dz \sec \alpha \sin \delta$  in Eq. (3), Solving and neglecting smaller term  $2K_p \gamma_1 \pi r_1 (dz^2/2) \sec \alpha \sin \delta$ ,  $K_p \gamma_1 \pi z dr_1 dz \sec \alpha \sin \delta$ ,  $K_p \gamma_1 \pi D dr_1 dz \sec \alpha \sin \delta$  and  $K_p \gamma_1 \pi dr_1 (dz^2/2) \sec \alpha \sin \delta$  ( $dz^2/2$ ,  $dr_1 dz$  and  $dr_1 dz^2/2$ ) may be small because  $dz$  and  $dr_1$  are small so that the product of the multiplication can be very small), results Eq. (4).

$$-\sigma(2\pi r_1 dr_1) - d\sigma \pi r_1^2 - 2K_p \gamma_1 \pi r_1 z dz \sec \alpha \sin \delta - 2K_p \gamma_1 \pi r_1 D dz \sec \alpha \sin \delta + \gamma_1 \pi r_1^2 dz = 0 \quad (4)$$

Dividing the Eq. (4) by  $\pi r_1^2$  results Eq. (5)

$$-2\sigma \left( \frac{dr_1}{r_1} \right) - d\sigma - 2K_p \gamma_1 \left( \frac{z}{r_1} \right) dz \sec \alpha \sin \delta - 2K_p \gamma_1 \left( \frac{D}{r_1} \right) dz \sec \alpha \sin \delta + \gamma_1 dz = 0 \quad (5)$$

Neglecting smaller term  $-2\sigma(dr_1 / r_1)$  in Eq. (5), and rewriting Eq. (5) results Eq. (6) because  $r_1$  is more in comparison to  $dr_1$  so the term  $dr_1 / r_1$  is very less and its product with  $-2\sigma$  is very less as compared to other terms in Eq. (5) and hence can be neglected.

$$-d\sigma - 2K_p \gamma_1 \left( \frac{z}{r_1} \right) dz \sec \alpha \sin \delta - 2K_p \gamma_1 \left( \frac{D}{r_1} \right) dz \sec \alpha \sin \delta + \gamma_1 dz = 0 \quad (6)$$

After performing the indefinite integration of Eq. (6), results Eq. (7)

$$\sigma = -K_p \gamma_1 \left( \frac{z^2}{r_1} \right) \sec \alpha \sin \delta - 2K_p \gamma_1 \left( \frac{Dz}{r_1} \right) \sec \alpha \sin \delta + \gamma_1 z + C \quad (7)$$

where,  $C$  is integration constant whose value is to be determined by applying boundary conditions

The boundary condition at the base of the circular footing are

$$\text{At } Z = 0, \sigma = q_{ult} \text{ and } r_1 = r' = D'/2$$

After applying the above boundary condition to the Eq. (7)

$$C = q_{ult} \quad (8)$$

The boundary condition at the interface of sand and clay layer are

$$\text{At } Z = H, \sigma = \sigma + d\sigma = q_b \text{ and } r_1 = \frac{D'}{2} + H \tan \alpha$$

After applying the above boundary condition to the Eq. (7) and substituting the value of  $C$  results Eq. (9)

$$q_b = -K_p \gamma_1 \left( \frac{2H^2}{D' + 2H \tan \alpha} \right) \sec \alpha \sin \delta - 2K_p \gamma_1 \left( \frac{2DH}{D' + 2H \tan \alpha} \right) \sin \delta \sec \alpha + \gamma_1 H + q_{ult} \quad (9)$$

Rearranging Eq. (9), the expression for  $q_{ult}$  will be as under

$$q_{ult} = q_b + K_p \gamma_1 \left( \frac{2H^2}{D' + 2H \tan \alpha} \right) \sec \alpha \sin \delta + 4K_p \gamma_1 \left( \frac{DH}{D' + 2H \tan \alpha} \right) \sin \delta \sec \alpha - \gamma_1 H \quad (10)$$

where,  $K_p$  is the coefficient of passive earth pressure whose value is taken from Rankine passive earth pressure theory.  $K_p$  also varies with the angle of shearing resistance  $\phi_1$  on the assumed failure surface.

$$K_p (\text{rankine}) = K_p \cdot \cos \delta$$

$$K_p = \frac{1}{\cos \delta} \cdot \left( \frac{1 + \sin \phi}{1 - \sin \phi} \right)$$

In the absence of equations for the determination of  $K_p$  for the curved surfaces in literature, the  $K_p$  (rankine) has been used.

Simplifying the Eq. (10), results Eq. (11)

$$q_{ult} = q_b + K_p \gamma_1 \sec \alpha \sin \delta \left( \frac{2H(H + 2D)}{D' + 2H \tan \alpha} \right) - \gamma_1 H \quad (11)$$

where,  $q_b$  is the ultimate bearing capacity of circular footing on a very thick bed of the lower soft saturated clay layer.

$$q_b = cN_c s_c + q \quad (12)$$

where,  $s_c = 1.3$  for circular footing

The non dimensional expression for  $q_b$  for Eq. (12) can be written as follows

$$\frac{q_b}{\gamma_1 D'} = \left( \frac{cN_c s_c + q}{\gamma_1 D'} \right) \quad (13)$$

Rewriting Eq. (11), and substituting Eq. (13), the equation for  $q_{ult}$  is given below

$$q_{ult} = cN_c s_c + q + K_p \gamma_1 \sec \alpha \sin \delta \left( \frac{2H(H + 2D)}{D' + 2H \tan \alpha} \right) - \gamma_1 H \quad (14)$$

The non dimensional expression for  $q_{ult}$  for Eq. (14) can be written as follows

$$\frac{q_{ult}}{\gamma_1 D'} = \left( \frac{cN_c s_c + q}{\gamma_1 D'} \right) + K_p \left( \frac{2H^2}{D'(D' + 2H \tan \alpha)} \right) \sec \alpha \sin \delta + \frac{4K_p DH}{D'(D' + 2H \tan \alpha)} \sin \delta \sec \alpha - \frac{H}{D'} \quad (15)$$

which on simplification results Eq. (16)

$$\frac{q_{ult}}{\gamma_1 D'} = \left( \frac{cN_c s_c + q}{\gamma_1 D'} \right) + 2K_p H \left( \frac{H + 2D}{D'(D' \cos \alpha + 2H \sin \alpha)} \right) \sin \delta - \frac{H}{D'} \quad (16)$$

#### 4. PARAMETRIC STUDY

Results are presented in the graphical form for the variation of non-dimensional parameter (Eq. (16)) with  $H/D'$ ,  $c/\gamma_1 D'$  and  $\alpha$ . The various parameters were varied as follows.

- Non-Dimensional parameter ( $c/\gamma_1 D'$ ) = 0.5 and 1.0
- The friction angle of the sand layer ( $\phi$ ) = 30°, 35°, 40° and 45°
- Mobilised angle of shearing resistance ( $\delta$ ) =  $\phi$  and  $2\phi/3$
- Load spread angle ( $\alpha$ ) in sand layer = 0° and 30°
- Non-Dimensional parameter ( $H/D'$ ) = 0.5 to 4.0 at an interval of 0.5.

For the parametric study, a circular footing, having a diameter of 1.909 m and thickness 0.32 m is resting on the surface of a sand layer having a thickness of 3.818 m. The soil properties of the sand layer were  $\gamma_1 = 22 \text{ kN/m}^3$ ,  $\phi = 30^\circ$  and relative density ( $D_r$ ) ranged from 30% to 32%. The sand layer rests on a soft, saturated clay layer having the undrained shear strength of  $c = 21 \text{ kN/m}^2$ . The variation of non-dimensional parameter  $q_{ult} / \gamma_1 D'$  with  $H/D'$  ratio for the case when footing rests on surface *i.e.*, ( $D/D'$ ) = 0,  $\alpha = 0$ ,  $\delta = \phi$  and  $c/\gamma_1 D' = 0.5$  and 1.0 are shown in Figs. 4 and 5 respectively. The curves for the case when  $\alpha = 0^\circ$  and  $30^\circ$ ,  $\delta = \phi$  and  $2\phi/3$ , ( $D/D'$ ) = 0 and  $c/\gamma_1 D' = 0.5, 1.0$  are shown in Figs. 8 and 9 respectively. The effect of various parameters on the non-dimensional parameter  $q_{ult} / \gamma_1 D'$  were studied and discussed in the following section.

### 4.1 Effect of $c/\gamma_1 D'$ on Non-Dimensional Parameter

$$q_{ult} / \gamma_1 D'$$

In order to study the effect of  $c/\gamma_1 D'$  on the non dimensional parameter  $q_{ult} / \gamma_1 D'$  for the case when  $\gamma_1 = 22 \text{ kN/m}^3$ ,  $c = 20 \text{ kN/m}^2$ ,  $t = 0.32 \text{ m}$ ,  $\alpha = 0^\circ$ ,  $(H/D') = 0.5$ ,  $\delta = \phi$  and  $2\phi/3$ , the results are shown in Fig. 4(a). Study of this figure reveals that with the increase in  $c/\gamma_1 D'$  from 0.5 to 2.0, the  $q_{ult} / \gamma_1 D'$  increases as it is obvious due to propotionate relation between  $q_{ult} / \gamma_1 D'$  and  $c/\gamma_1 D'$ . A similar study for the case when  $\alpha = 30^\circ$  keeping other parameters same, the results for the variation of  $q_{ult} / \gamma_1 D'$  with  $c/\gamma_1 D'$  are shown in Fig. 4(b). Study of this figure reveals that the trend of variation between  $q_{ult} / \gamma_1 D'$  with  $c/\gamma_1 D'$  is similar to the case when  $\alpha = 0^\circ$ , but the values of  $q_{ult} / \gamma_1 D'$  are lower for  $\phi = 30^\circ$ ,  $35^\circ$ ,  $40^\circ$  and  $45^\circ$  in comparison to the case when  $\alpha = 0^\circ$ . This is due to the fact that  $q_{ult} / \gamma_1 D'$  is in inverse proportion to the load spread angle  $\alpha$ . These observations are in agreement with the earlier study reported by Abdulhahz et al. (2005) for stiff sand layer overlying soft clay layer.

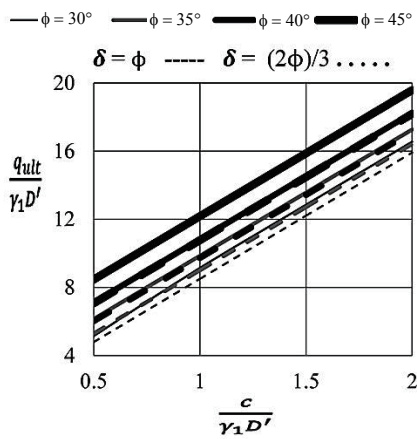

(a)  $\alpha = 0^\circ$

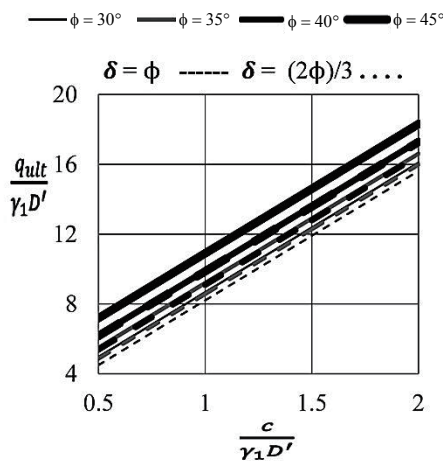

(b)  $\alpha = 30^\circ$

**Fig. 4** Plot depicting the variation of  $q_{ult} / \gamma_1 D'$  with  $c/\gamma_1 D'$  when  $H/D' = 0.5$  and  $D/D' = 0$

### 4.2 Comparison and Validation

The expression for the calculation of the ultimate bearing capacity of a footing on a two layer soil suggested by Meyerhof (1974) is the most widely known and the same is used here for comparison with the proposed Eq. (16). The results for the comparison are shown in Figs. 5 and 6 for different cases. These figures also include the experimental results for the circular footing resting on dense sand underlain by soft saturated clay and reported by Ibrahim (2014) for validation. The comparison and validation is carried out for higher as well as lower values of load spread angle ( $\alpha$ ) and  $\delta = \phi$  with  $\phi$  ranging from  $30^\circ$  to  $45^\circ$ . For the higher value of load spread angle ( $\alpha = 30^\circ$ ), study of Figs. 5(a) to 5(d) reveals that the equation proposed by Meyerhof (1974) in general overestimate the ultimate bearing capacity, whereas there was a good agreement between the results from the proposed Eq. (16) with the one obtained experimentally by Ibrahim (2014). Further study of Figs. 5(a), 5(b), 5(c) and 5(d) reveals that for  $\delta = \phi$ ,  $0.5 < H/D' < 1.5$ , the difference between the variation of  $q_{ult} / \gamma_1 D'$  with  $(H/D')$  for  $\phi = 30^\circ$ ,  $\phi = 35^\circ$ ,  $\phi = 40^\circ$  and  $\phi = 45^\circ$  using Meyerhof (1974) equation and the proposed Eq. (16) is comparable whereas for  $1.5 < H/D' < 4$ , the difference is large between the results from these two equations. Further, for the lower value of load spread angle ( $\alpha = 0^\circ$ ), the variation of  $q_{ult} / \gamma_1 D'$  with  $(H/D')$  ratio as shown in Figs. 6(a) to 6(d) reveals that the results are comparable using proposed Eq. (16) and the one obtained using Meyerhof (1974) whereas the deviation is large between the results from the proposed Eq. (16) and the one reported experimentally by Ibrahim (2014) for the circular footing. Further, better results may be obtained from the proposed Eq. (16) for a lower value of the load spread angle as all the theoretical equations developed in literature possess a large number of assumptions leading to variations among  $q_{ult} / \gamma_1 D'$  calculated using various models. Similar observations were also reported by Kenny and Andrawes (1997) for the case of the strip footing resting on layered profile and using the projected area approach.

### 4.3 Effect of Soil Friction Angle $\phi$ on Non-Dimensional Parameter $q_{ult} / \gamma_1 D'$

To study the effect of soil friction on the non dimensional parameter  $q_{ult} / \gamma_1 D'$  for the case when  $\gamma_1 = 22 \text{ kN/m}^3$ ,  $c = 20 \text{ kN/m}^2$ ,  $t = 0.32 \text{ m}$ ,  $D' = 1.909 \text{ m}$ ,  $0.9545 \text{ m}$  and  $\alpha = 0^\circ$  and  $30^\circ$ , the results are shown in Figs. 8(a) to 8(d). For the case when  $\alpha = 0^\circ$ , study of Figs. 8(a) to 8(b) reveal that with the increase in  $\phi$  from  $30^\circ$  to  $45^\circ$ , there is a gradual curvilinear increase and a sharp increase in  $q_{ult} / \gamma_1 D'$  when  $0.5 < H/D' < 1.5$  and  $1.5 < H/D' < 4$  respectively. A similar study for the case when  $\alpha = 30^\circ$  keeping other parameters same, the results are shown in Figs. 8(c) to 8(d). Study of Figs. 8(c) to 8(d) reveal that with the increase in  $\phi$  from  $30^\circ$  to  $45^\circ$ , there is a gradual increase, linear increase and sharp increase in  $q_{ult} / \gamma_1 D'$  for  $\phi = 30^\circ$ ,  $\phi = 35^\circ$  and  $\phi = 40^\circ$ ;  $\phi = 45^\circ$  respectively. This increase in  $q_{ult} / \gamma_1 D'$  may be attributed to the increase in the friction angle of soil, thereby resulting in an increase in the overall bearing capacity of the layered soil for all values of load spread angle.



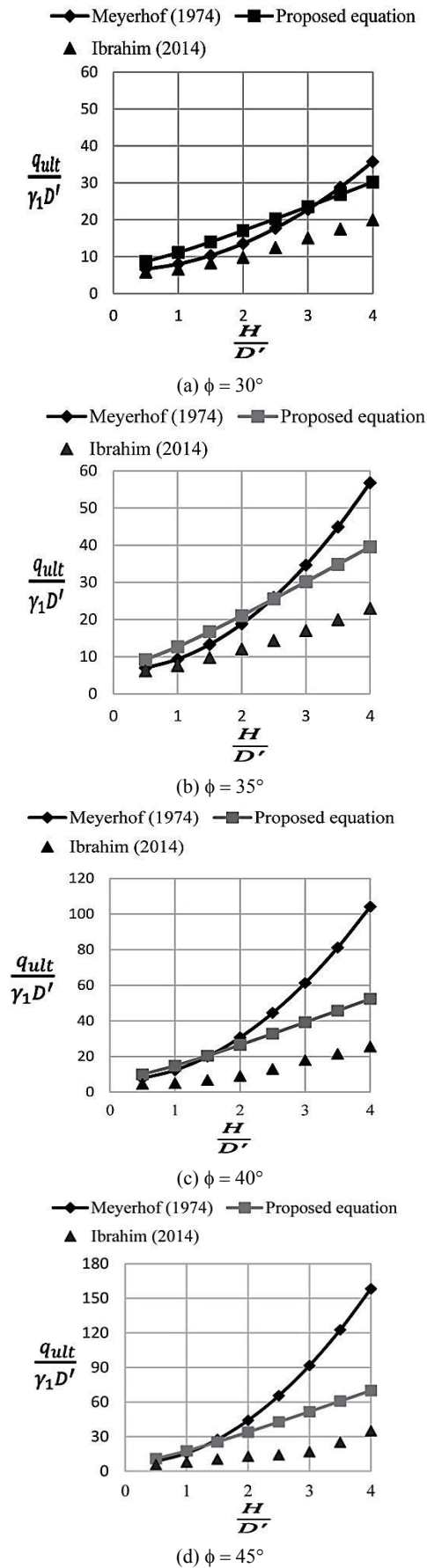

Fig. 5 Plot depicting the variation of  $q_{ult} / \gamma_1 D'$  with  $H/D'$  when  $c/\gamma_1 D' = 1.0$ ,  $\alpha = 30^\circ$ ,  $\delta = \phi$  and  $D/D' = 0$

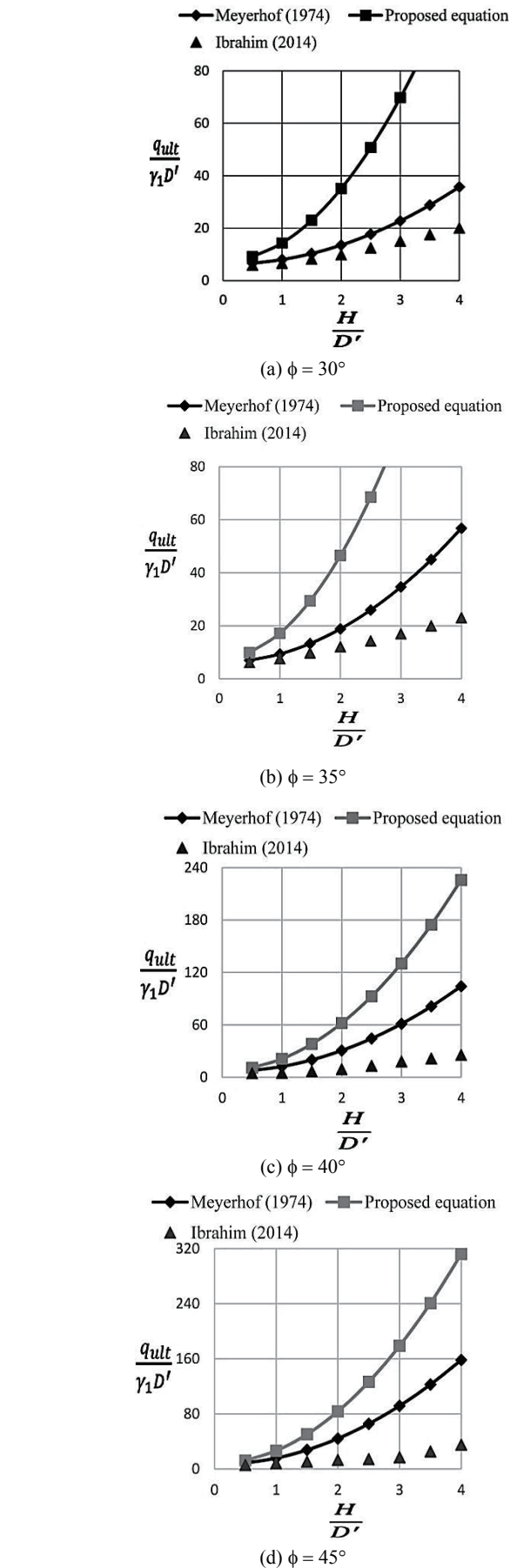

Fig. 6 Plot depicting the variation of  $q_{ult} / \gamma_1 D'$  with  $H/D'$  when  $c/\gamma_1 D' = 1.0$ ,  $\alpha = 0^\circ$ ,  $\delta = \phi$  and  $D/D' = 0$

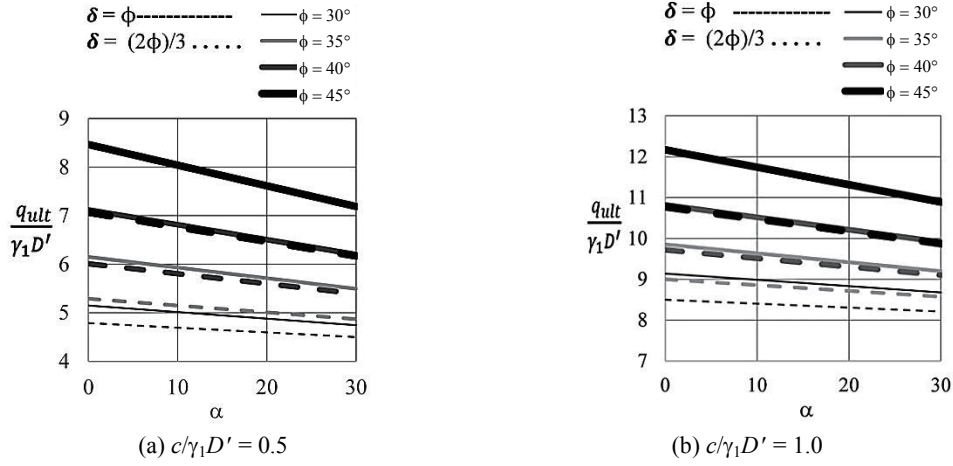

Fig. 7 Plot depicting the variation of  $q_{ult} / \gamma_1 D'$  with  $\alpha$  when  $H/D' = 0.5$  and  $D/D' = 0$

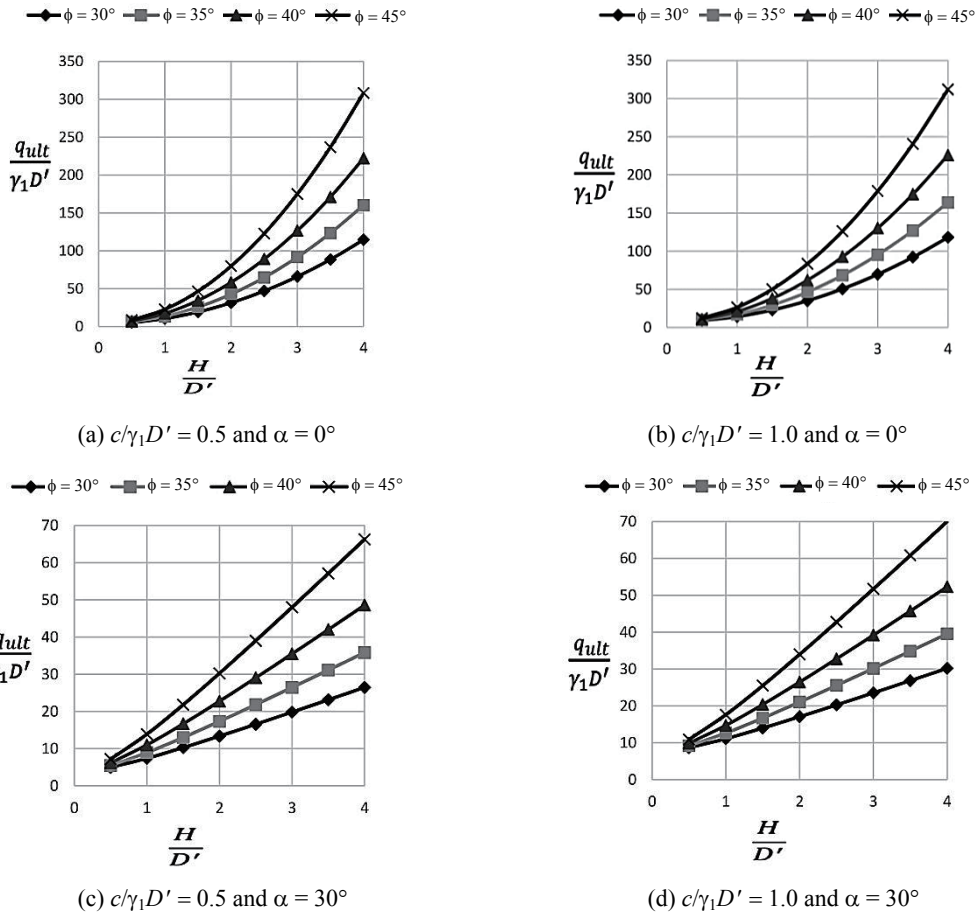
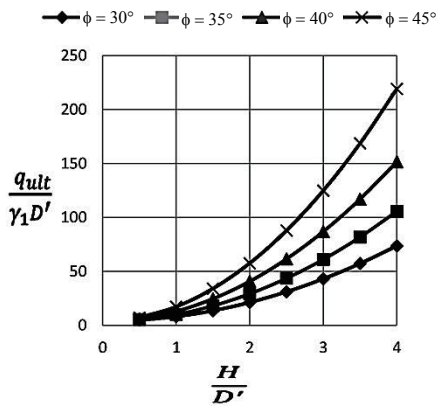

Fig. 8 Plot depicting the variation of  $q_{ult} / \gamma_1 D'$  with  $H/D'$  when  $\delta = \phi$  and  $D/D' = 0$

**4.4 Effect of Mobilised Angle of Shearing Resistance  $\delta$  on Non Dimensional Parameter  $q_{ult} / \gamma_1 D'$**

The effect of mobilised angle of shearing resistance ( $\delta$ ) on non dimensional parameter  $q_{ult} / \gamma_1 D'$  for the case when  $\gamma_1 = 22 \text{ kN/m}^3$ ,  $c = 20 \text{ kN/m}^2$ ,  $t = 0.32 \text{ m}$ ,  $D' = 1.909 \text{ m}$ ,  $0.9545 \text{ m}$  and  $\alpha = 0^\circ$  and  $30^\circ$  are shown in Figs. 4, 7, 8 and 9 respectively for  $\phi = 30^\circ, 35^\circ, 40^\circ$  and  $45^\circ$ . These figures reveal that the  $q_{ult} / \gamma_1 D'$  marginally decrease with the decrease in  $\delta$  from  $\phi$  to

$2\phi/3$  for  $\phi = 30^\circ, 35^\circ, 40^\circ$  and  $45^\circ$ . This marginal decrease in  $q_{ult} / \gamma_1 D'$  with the decrease in  $\delta$  is attributed to the fact that the proposed Eq. (16) is in direct proportion to the sine of mobilised angle of shearing resistance ( $\delta$ ). The mobilised angle of shearing resistance ( $\delta$ ) is decreased from  $\phi$  to  $2\phi/3$  resulting marginal decrease in  $q_{ult} / \gamma_1 D'$ . Further, the passive pressure component acting in vertical direction is also decreasing to some extent with the decrease in friction angle from  $\phi$  to  $2\phi/3$ .



(a)  $c/\gamma_1 D' = 0.5$  and  $\alpha = 0^\circ$

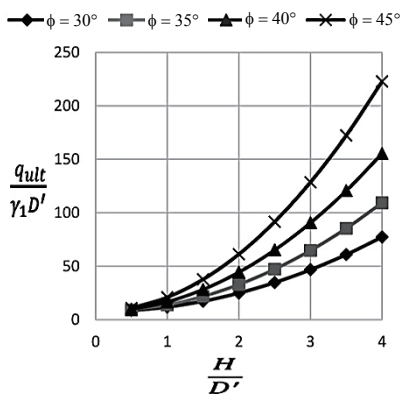

(b)  $c/\gamma_1 D' = 1.0$  and  $\alpha = 0^\circ$

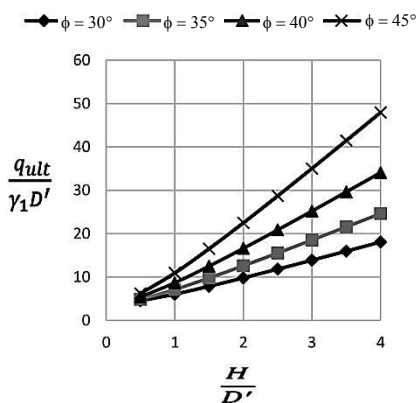

(c)  $c/\gamma_1 D' = 0.5$  and  $\alpha = 30^\circ$

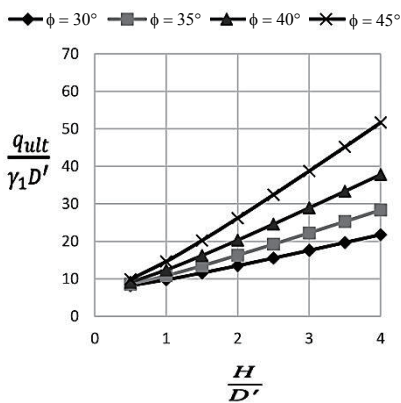

(d)  $c/\gamma_1 D' = 1.0$  and  $\alpha = 30^\circ$

Fig. 9 Plot depicting the variation of  $q_{ult}/\gamma_1 D'$  with  $H/D'$  when  $\delta = 2\phi/3$  and  $D/D' = 0$

#### 4.5 Effect of Load Spread Angle $\alpha$ on the Non Dimensional Parameter $q_{ult}/\gamma_1 D'$

The effect of load spread angle of shearing resistance  $\alpha$  on non dimensional parameter  $q_{ult}/\gamma_1 D'$  for the case when  $\gamma_1 = 22 \text{ kN/m}^3$ ,  $c = 20 \text{ kN/m}^2$ ,  $t = 0.32 \text{ m}$ ,  $c/\gamma_1 D' = 0.5, 1.0$  and  $\phi = 30^\circ, 35^\circ, 40^\circ$  and  $45^\circ$  are shown in Figs. 7(a) and 7(b). These figures reveal that the  $q_{ult}/\gamma_1 D'$  decrease with the increase in  $\alpha$  from  $0^\circ$  to  $30^\circ$ . This decrease in  $q_{ult}/\gamma_1 D'$  with the increase in  $\alpha$  is attributed to the fact that the load transfer to the interface will get reduced due to increase in load spread angle thereby resulting decrease in the non-dimensional parameter  $q_{ult}/\gamma_1 D'$  and vice versa.

#### 4.6 Effect of $H/D'$ on the Non Dimensional Parameter $q_{ult}/\gamma_1 D'$

The effect of  $H/D'$  on the non dimensional parameter  $q_{ult}/\gamma_1 D'$  for the case when  $\gamma_1 = 22 \text{ kN/m}^3$ ,  $c = 20 \text{ kN/m}^2$ ,  $t = 0.32 \text{ m}$  and  $c/\gamma_1 D' = 0.5, 1.0$  are shown in Figs. 8 and 9 for  $\delta = \phi, 2\phi/3$  and  $\phi = 30^\circ, 35^\circ, 40^\circ$  and  $45^\circ$ . Study of these figures reveals that with the increase in  $(H/D')$  ratio, there is an increase in the non dimensional parameter  $q_{ult}/\gamma_1 D'$ . This is attributed to the fact that with the increase in thickness of the sand layer resistance offered by the soil to footing will be more thereby resulting in an increase in bearing capacity of layered soil. These observations are in agreement with the earlier study reported by Hanna (1982) for the circular footing resting on strong sand overlying weak sand.

### 5. CONCLUDING REMARKS

The paper presents the equation for the bearing capacity of a circular footing resting on layered soil using punching shear failure mechanism following projected area approach and subjected to vertical concentric load. The equation presented in this paper contains the properties of the upper and lower layer. The calculation of bearing capacity is based upon certain assumptions. Parametric study is carried out and the results were compared and validated with other theoretical equation/experimental results available in the literature. The proposed equation appears to be effective as the results obtained are in good agreement with the plate load tests conducted by Ibrahim (2014) whereas the equation proposed by Meyerhof (1974) overestimate the ultimate bearing capacity for high values of load spread angle. For,  $0.5 < H/D' < 1.5$ , the agreement between the proposed equation and Meyerhof equation as well as the experimental results reported in literature is good whereas the deviation is large for  $1.5 < H/D' < 4$  for all values of load spread angle. On the basis of results and discussion made in this paper in the previous sections, the study brings forth the following conclusions.

1. The analysis indicate that in general with the increase in  $H/D'$ , there is an increase in non dimensional parameter  $q_{ult}/\gamma_1 D'$ .
2. With the increase in load spread angle there is decrease in non dimensional parameter  $q_{ult}/\gamma_1 D'$ .



3. With the decrease in  $\delta$  from  $\phi$  to  $2\phi/3$  there is a marginal decrease in non dimensional parameter  $q_{ult} / \gamma_1 D'$ .
4. With the increase in friction angle of soil there is an increase in non dimensional parameter  $q_{ult} / \gamma_1 D'$ .
5. With the increase in non dimensional parameter  $c/\gamma_1 D'$  there is an increase in non dimensional parameter  $q_{ult} / \gamma_1 D'$ .

## NOTATIONS

$C$	Integration constants
$c$	Cohesion, $\text{kN/m}^2$
$c/\gamma_1 D'$	Non-dimensional parameter (Ratio of cohesion to the product of density and diameter of circular footing)
$D$	Depth of footing, $m$
$D'$	Diameter of circular footing, $m$
$D/D'$	Non-dimensional parameter (Ratio of depth to the diameter of circular footing)
$D_r$	Relative density of dense sand
$H$	Total thickness of upper layer-Depth of footing, $m$
$H/D'$	Non-dimensional parameter
$K_p$	Coefficient of passive earth pressure value depends on shearing resistance $\phi_1$
$NC$	Normally consolidated
$N_c$	Bearing capacity factor corresponding to lower clay layer
$OC$	Over consolidated
$P_p$	The total passive pressure on frustum
$q$	Surcharge loading, $\text{kN/m}^2$
$q_b$	Ultimate bearing capacity of circular footing on a very thick bed of the lower clay layer, $\text{kN/m}^2$
$q_{ult} / \gamma_1 D'$	Non-dimensional parameter (Ratio of ultimate bearing capacity to the product of density and diameter of circular footing)
$r'$	Radius of circular footing, $m$
$s_c$	Shape factor
$t$	Thickness of circular footing, $m$
$z$	Depth of the curved strip from base of footing, $m$
$dP_p_v$	Passive earth pressure acting along the vertical direction
$dP_p$	Passive earth pressure on strip of thickness $dz$
$d\sigma$	Increase in vertical stress, $\text{kN/m}^2$
$dz$	Thickness of curved strip, $m$

## Greek Symbols

$\alpha$	Dispersion angle of the load through circular footing on upper layer
$\delta$	Mobilised angle of shearing resistance, degree
$\phi$	Angle of friction of the soil, degree
$\gamma$	Density of the soil, $\text{kN/m}^3$
$\gamma_1$	Unit weight of upper stratum, $\text{kN/m}^3$
$\sigma$	Vertical stress, $\text{kN/m}^2$

## REFERENCES

- Abdulhaz, O., Al-Shenawy, A., Awad, A., and Al-Karni, A. (2005). "Derivation of bearing capacity equation for a two layered system of weak clay layer overlaid by dense sand layer." *Pertanika Journal of Science and Technology*, **13**(2), 213–235.
- Andrawes, K.Z., Al-Omari, R.R., and Kirkpatrick, W.M. (1996). "Bearing capacity of a strip foundation on a sand layer overlying a smooth rigid stratum." *Geotechnical and Geological Engineering*, **14**(3), 227–236.
- Carlos, A. F. (2004). "Ultimate bearing capacity of shallow foundations on layered soils." MSc Thesis, Civil and Environmental Engineering, Quebec: Concordia.
- Georgiadis, M. (1985). "Bearing capacity of gravity bases on layered soil." *Journal of Geotechnical Engineering*, ASCE, **111**(6), 712–729, [http://dx.doi.org/10.1061/\(ASCE\)0733-9410\(1985\)111:6\(712\)](http://dx.doi.org/10.1061/(ASCE)0733-9410(1985)111:6(712)).
- Hanna, A.M. (1981b). "Foundations on strong sand overlying weak sand." *Journal of the Geotechnical Engineering Division*, ASCE, **107**(7), 915–927.
- Hanna, A.M. (1982). "Bearing capacity of foundations on a weak sand layer overlying a strong deposit." *Canadian Geotechnical Journal*, **19**(3), 392–396, <http://dx.doi.org/10.1139/t82-043>.
- Hanna, A.M. (1987). "Finite element analysis of footings on layered soils." *Mathematical Modelling*, **9**(11), 813–819, [http://dx.doi.org/10.1016/0270-0255\(87\)90501-X](http://dx.doi.org/10.1016/0270-0255(87)90501-X).
- Hanna, A.M. and Meyerhof, G. (1979). "Ultimate bearing capacity of foundations on a three-layer soil, with special reference to layered sand." *Canadian Geotechnical Journal*, **16**(2), 412–414, <http://dx.doi.org/10.1139/t79-042>.
- Hanna, A.M. and Meyerhof, G.G. (1980). "Design charts for ultimate bearing capacity of foundations on sand overlying soft clay." *Canadian Geotechnical Journal*, **17**, 300–303, [http://dx.doi.org/10.1061/\(ASCE\)1090-0241\(2007\)133:5\(502\)](http://dx.doi.org/10.1061/(ASCE)1090-0241(2007)133:5(502)).
- Hanna, A.M., and Meyerhof, G.G. (1981). "Experimental evaluation of bearing capacity of footings subjected to inclined loads." *Canadian Geotechnical Journal*, **18**(4), 599–603.
- Huang, M. and Qin, H-L. (2009). "Upper-bound multi-rigid-block solutions for bearing capacity of two-layered soils." *Computers and Geotechnics*, **36**(3), 525–529, <http://dx.doi.org/10.1016/j.compgeo.2008.10.001>.
- Ibrahim, K.M.H.I. (2014). "Bearing capacity of circular footing resting on granular soil overlying soft clay." *HBRC Journal*, <http://dx.doi.org/10.1016/j.hbrj.2014.07.004>.
- Kalinli, A., Acar, M.C., and Gündüz, Z. (2011). "New approaches to determine the ultimate bearing capacity of shallow foundations based on artificial neural networks and ant colony optimization." *Engineering Geology*, **117**(1-2), 29–38, <http://dx.doi.org/10.1016/j.enggeo.2010.10.002>.
- Kenny, M.J. and Andrawes, K.Z. (1997). "The bearing capacity of footings on sand layer overlying soft clay." *Geotechniques*, **47**, 339–345.
- Kumar, J. and Kouzer, K.M. (2007). "Effect of footing roughness on bearing capacity factor  $N_Y$ ." *Journal of Geotechnical and Geoenvironmental Engineering*, ASCE, **133**(5), 502–511.
- Kuo, Y.L., Jaksa, M.B., Lyamin, A.V., and Kaggwa, W.S. (2009). "ANN-based model for predicting the bearing capacity of strip footing on multi-layered cohesive soil." *Computers and Geotechnics*, **36**(3), 503–516, <http://dx.doi.org/10.1016/j.compgeo.2008.07.002>.
- Merifield, R.S., Sloan, S.W., and Yu, H.S. (1999). "Rigorous solutions for the bearing capacity of two layered clay soils." *Geotechnique*, **49**(4), 471–490.

- Meyerhof, G.G. (1974). "Ultimate bearing capacity of footings on sand layer overlying clay." *Canadian Geotechnical Journal*, **11**, 223–229.
- Michalowski, R.L. and Shi, L. (1995). "Bearing capacity of footings over two-layer foundations soil." *Journal of Geotechnical Engineering ASCE*, **121**(5), 421–428, [http://dx.doi.org/10.1061/\(ASCE\)0733-9410\(1995\)121:5\(421\)](http://dx.doi.org/10.1061/(ASCE)0733-9410(1995)121:5(421)).
- Oda, M. and Win, S. (1990). "Ultimate bearing capacity tests on sand with clay layer." *Journal Geotechnical Engineering*, **116**(12), 1902–1906.
- Okamura, M., Takemura, J., and Kimura, T. (1998). "Bearing capacity predictions of sand overlying clay based on limit equilibrium methods." *Soils and Foundations*, **38**(1), 181–194, <http://dx.doi.org/10.3208/sandf.38.181>.
- Padmini, D., Ilamparuthi, K., and Sudheer, K.P. (2008). "Ultimate bearing capacity prediction of shallow foundations on cohesionless soils using neurofuzzy models." *Computers and Geotechnics*, **35**(1), 33–46, <http://dx.doi.org/10.1016/j.compgeo.2007.03.001>.
- Purushothamaraj, P., Ramiah, B.K., and Venkatakrisna Rao, K.N. (1974). "Bearing capacity of strip footings in two layered cohesive-friction soils." *Canadian Geotechnical Journal*, **11**(1), 32–45, <http://dx.doi.org/10.1139/t74-003>.
- Shoaei, M.D., Alkarni, A., Noorzaei, J., Jaafar, M.S., and Huat, B.B.K. (2012). "Review of available approaches for ultimate bearing capacity of two-layered soils." *Journal of Civil Engineering and Management*, **18**(4), 469–482.
- Szypcio, Z. and Dolżyk, K. (2006). "The bearing capacity of layered subsoil." *Studia Geotechnica et Mechanica*, **28**(1), 45–60.
- Taiebat, H.A. and Carter, J.P. (2010). "A failure surface for circular footings on cohesive soils." *Geotechnique*, **60**(4), 265–273.
- Yin, J.-H., Wang, Y.-J., and Selvadurai, A.P.S. (2001). "Influence of nonassociativity on the bearing capacity of a strip footing." *Journal of Geotechnical and Geoenvironmental Engineering, ASCE*, **127**(11), 985–989, [http://dx.doi.org/10.1061/\(ASCE\)1090-0241\(2001\)127:11\(985\)](http://dx.doi.org/10.1061/(ASCE)1090-0241(2001)127:11(985)).
- Zhang, Q. and Luan, M. (2008). "Study on ultimate bearing capacity of two-layered subsoil under horizontal and vertical loading." *Geotechnical Engineering for Disaster Mitigation and Rehabilitation*, 1093–1100.
- Zhu, M. (2004). "Bearing capacity of strip footings on two-layer clay soil by finite element method." *Proc. of the ABAQUS Users' Conference*, June, 2004, Massachusetts, Boston, 776–787.
- Zhu, M. and Michalowski, R.L. (2005). "Bearing capacity of rectangular footings on two-layer clay." *The 16th International Conference of Soil Mechanics and Geotechnical Engineering*, 12–16 September, 2005, Osaka, Japan, 997–1000.